



SGM7222

High Speed USB 2.0 (480Mbps) DPDT Analog Switch

GENERAL DESCRIPTION

The SGM7222 is a high-speed, low-power double-pole/double-throw (DPDT) analog switch that operates from a single 1.8V to 4.3V power supply.

SGM7222 is designed for the switching of high-speed USB 2.0 signals in handset and consumer applications, such as cell phones, digital cameras, and notebooks with hubs or controllers with limited USB I/Os.

The SGM7222 has low bit-to-bit skew and high channel-to-channel noise isolation, and is compatible with various standards, such as high-speed USB 2.0 (480 Mbps). Each switch is bidirectional and offers little or no attenuation of the high-speed signals at the outputs. Its bandwidth is wide enough to pass high-speed USB 2.0 differential signals (480 Mb/s) with good signal integrity.

The SGM7222 contains special circuitry on the D+/D- pins which allows the device to withstand a V_{BUS} short to D+ or D- when the USB devices are either powered off or powered on.

SGM7222 is available in Green TQFN-1.8×1.4-10L, MSOP-10 and UTQFN-1.8×1.4-10L packages. It operates over an ambient temperature range of -40°C to +85°C.

APPLICATIONS

- Route Signals for USB 2.0
- MP3 and Other Personal Media Players
- Digital Cameras and Camcorders
- Portable Instrumentation
- Set-Top Boxes
- PDA's

FEATURES

- R_{ON} is Typically 4.5Ω at 3.0V
- Low Bit-to-Bit Skew: 50ps (TYP)
- Voltage Operation: 1.8V to 4.3V
- Fast Switching Times:
 - t_{ON} 10ns
 - t_{OFF} 22ns
- Low Crosstalk: -41dB at 250MHz
- Power-Off Protection when $V_+ = 0V$, D+/D- Pins can Tolerate up to 5.25V
- High Off-Isolation: -35dB at 250MHz
- Rail-to-Rail Input and Output Operation
- Break-Before-Make Switching
- Extended Industrial Temperature Range: -40°C to +85°C
- Small Packages:
 - MSOP-10, TQFN-1.8×1.4-10L and
 - UTQFN-1.8×1.4-10L

BLOCK DIAGRAM

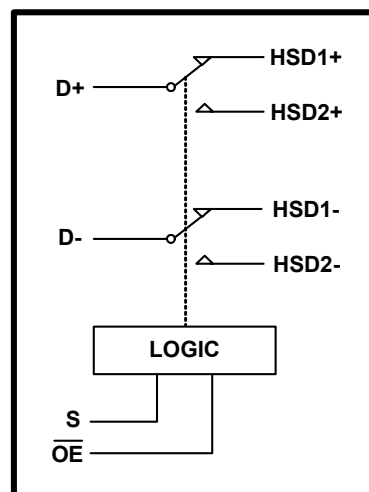

PACKAGE/ORDERING INFORMATION

MODEL	PIN-PACKAGE	SPECIFIED TEMPERATURE RANGE	ORDERING NUMBER	PACKAGE MARKING	PACKAGE OPTION
SGM7222	MSOP-10	-40°C to +85°C	SGM7222YMS10/TR	SGM7222YMS10	Tape and Reel, 3000
	TQFN-1.8×1.4-10L	-40°C to +85°C	SGM7222YWQ10/TR	7222	Tape and Reel, 3000
	UTQFN-1.8×1.4-10L	-40°C to +85°C	SGM7222YUWQ10/TR	7222	Tape and Reel, 3000

ABSOLUTE MAXIMUM RATINGS

V₊ to GND..... 0V to 4.6V
 Analog, Digital voltage range-0.3V to (V₊) + 0.3V
 Continuous Current HSDn or Dn.....±100mA
 Peak Current HSDn or Dn.....±150mA
 Operating Temperature Range.....-40°C to +85°C
 Junction Temperature..... 150°C
 Storage Temperature Range.....-65°C to +150°C
 Lead Temperature (Soldering, 10s).....260°C
 ESD Susceptibility
 HBM.....8000V
 MM.....400V

NOTE: Stresses beyond those listed under “Absolute Maximum Ratings” may cause permanent damage to the device. These are stress ratings only, and functional operation of the device at these or any other conditions beyond those indicated in the operational sections of the specifications is not implied. Exposure to absolute maximum rating conditions for extended periods may affect device reliability.

CAUTION

This integrated circuit can be damaged by ESD if you don't pay attention to ESD protection. SGMICRO recommends that all integrated circuits be handled with appropriate precautions. Failure to observe proper handling and installation procedures can cause damage. ESD damage can range from subtle performance degradation to complete device failure. Precision integrated circuits may be more susceptible to damage because very small parametric changes could cause the device not to meet its published specifications.

SGMICRO reserves the right to make any change in circuit design, specification or other related things if necessary without notice at any time. Please contact SGMICRO sales office to get the latest datasheet.

PIN CONFIGURATIONS (TOP VIEW)

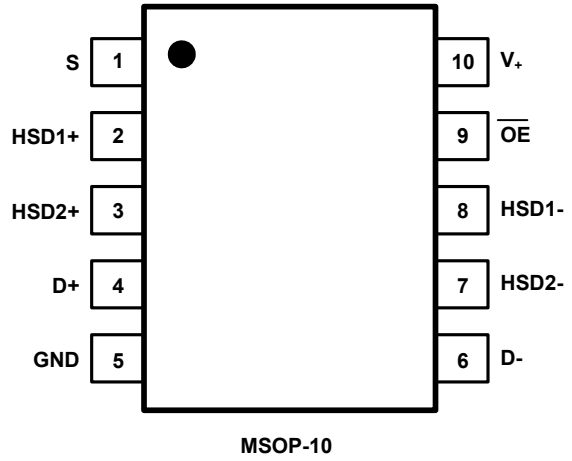
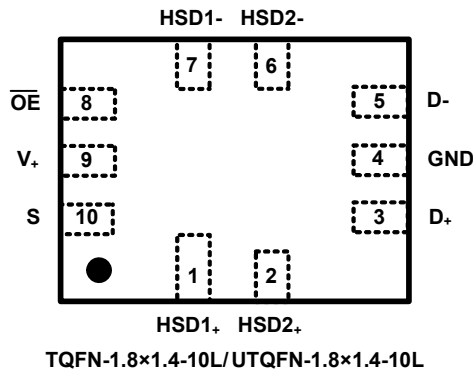

PIN DESCRIPTION

TQFN-1.8x1.4-10L/ UTQFN-1.8x1.4-10L	MSOP-10	NAME	FUNCTION
9	10	V ₊	Power Supply
4	5	GND	Ground
10	1	S	Select Input
8	9	\overline{OE}	Output Enable
1, 2	2, 3	HSD1+, HSD2+	Data Ports
7, 6	8, 7	HSD1-, HSD2-	
3, 5	4, 6	D+, D-	

FUNCTION TABLE

\overline{OE}	S	HSD1+ HSD1-	HSD2+ HSD2-
0	0	ON	OFF
0	1	OFF	ON
1	x	OFF	OFF

NOTE: Switches Shown For Logic "0" Input

ELECTRICAL CHARACTERISTICS

(V_+ = +1.8V to +4.3V, GND = 0V, V_{IH} = +1.6V, V_{IL} = +0.5V, T_A = -40°C to +85°C. Typical values are at V_+ = +3.3V, T_A = +25°C, unless otherwise noted.)

PARAMETER	SYMBOL	CONDITIONS	TEMP	MIN	TYP	MAX	UNITS
ANALOG SWITCH							
Analog I/O Voltage (HSD1+, HSD1-, HSD2+, HSD2-)	V_{IS}		-40°C to +85°C	0		V_+	V
On-Resistance	R_{ON}	V_+ = 3.0V, V_{IS} = 0V to 0.4V, I_D = 8mA, Test Circuit 1	+25°C		4.5	8.5	Ω
			-40°C to +85°C			9	
On-Resistance Match Between Channels	ΔR_{ON}	V_+ = 3.0V, V_{IS} = 0V to 0.4V, I_D = 8mA, Test Circuit 1	+25°C		0.15	0.6	Ω
			-40°C to +85°C			1.6	
On-Resistance Flatness	$R_{FLAT(ON)}$	V_+ = 3.0V, V_{IS} = 0V to 1.0V, I_D = 8mA, Test Circuit 1	+25°C		1.5	2.0	Ω
			-40°C to +85°C			2.6	
Power Off Leakage Current (D+, D-)	I_{OFF}	V_+ = 0V, V_D = 0V to 3.6V, V_S , V_{OE} = 0V or 3.6V	-40°C to +85°C			1	μ A
Increase in I_+ per Control Voltage	I_{CCT}	V_+ = 3.6V, V_S or V_{OE} = 2.6V	-40°C to +85°C			5	μ A
Source Off Leakage Current	$I_{HSD2(OFF)}$, $I_{HSD1(OFF)}$	V_+ = 3.6V, V_{IS} = 3.3V/0.3V, V_D = 0.3V/ 3.3V	-40°C to +85°C			1	μ A
Channel On Leakage Current	$I_{HSD2(ON)}$, $I_{HSD1(ON)}$	V_+ = 3.6V, V_{IS} = 3.3V/0.3V, V_D = 3.3V/0.3V or floating	-40°C to +85°C			1	μ A
DIGITAL INPUTS							
Input High Voltage	V_{IH}		-40°C to +85°C	1.6			V
Input Low Voltage	V_{IL}		-40°C to +85°C			0.5	V
Input Leakage Current	I_{IN}	V_+ = 3.0V, V_S , V_{OE} = 0V or V_+	-40°C to +85°C			1	μ A
DYNAMIC CHARACTERISTICS							
Turn-On Time	t_{ON}	V_{IS} = 0.8V, R_L = 50 Ω , C_L = 10pF, Test Circuit 2	+25°C		10		ns
Turn-Off Time	t_{OFF}		+25°C		22		ns
Break-Before-Make Time Delay	t_D	V_{IS} = 0.8V, R_L = 50 Ω , C_L = 10pF, Test Circuit 3	+25°C		4		ns
Propagation Delay	t_{PD}	R_L = 50 Ω , C_L = 10pF	+25°C		0.3		ns
Off Isolation	O_{ISO}	Signal = 0dBm, R_L = 50 Ω , f = 250MHz, Test Circuit 4	+25°C		-35		dB
Channel-to-Channel Crosstalk	X_{TALK}	Signal = 0dBm, R_L = 50 Ω , f = 250MHz, Test Circuit 5	+25°C		-41		dB
-3dB Bandwidth	BW	Signal = 0dBm, R_L = 50 Ω , C_L = 5pF, Test Circuit 6	+25°C		550		MHz
Channel-to-Channel Skew	t_{SKEW}	R_L = 50 Ω , C_L = 10pF	+25°C		0.05		ns
Charge Injection Select Input to Common I/O	Q	V_G = GND, C_L = 1.0nF, R_G = 0 Ω , Q = $C_L \times V_{OUT}$, Test Circuit 7	+25°C		11		pC
HSD+, HSD-, D+, D- ON Capacitance	C_{ON}		+25°C		6.5		pF
POWER REQUIREMENTS							
Power Supply Range	V_+		-40°C to +85°C	1.8		4.3	V
Power Supply Current	I_+	V_+ = 3.0V, V_S , V_{OE} = 0V or V_+	-40°C to +85°C			1	μ A

TYPICAL PERFORMANCE CHARACTERISTICS

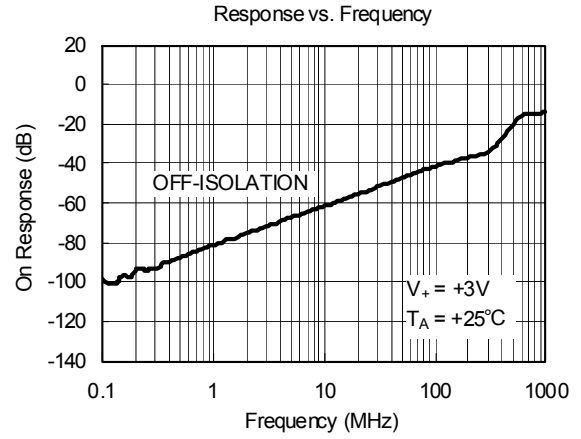
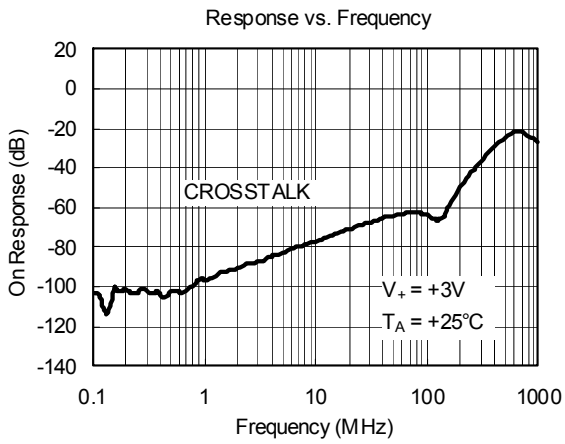

TEST CIRCUITS

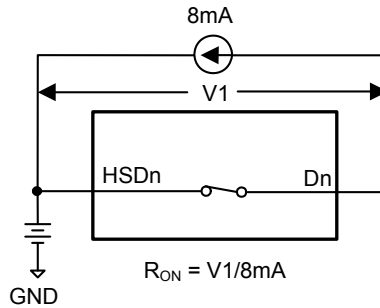

Test Circuit 1. On Resistance

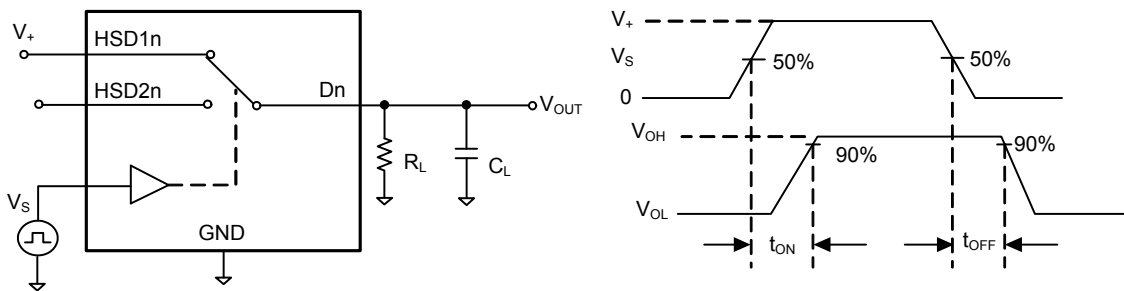

Test Circuit 2. Switching Times (t_{ON} , t_{OFF})

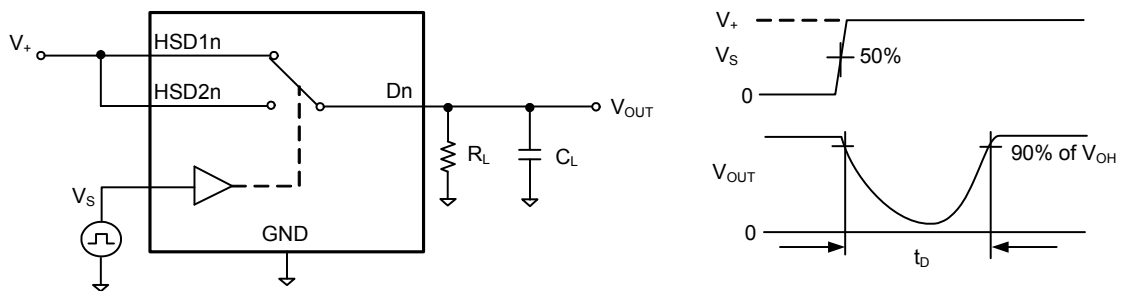

Test Circuit 3. Break-Before-Make Time (t_D)

TEST CIRCUITS (Cont.)

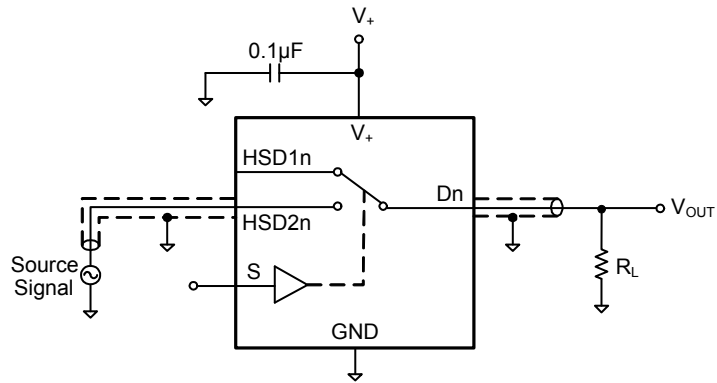

Test Circuit 4. Off Isolation

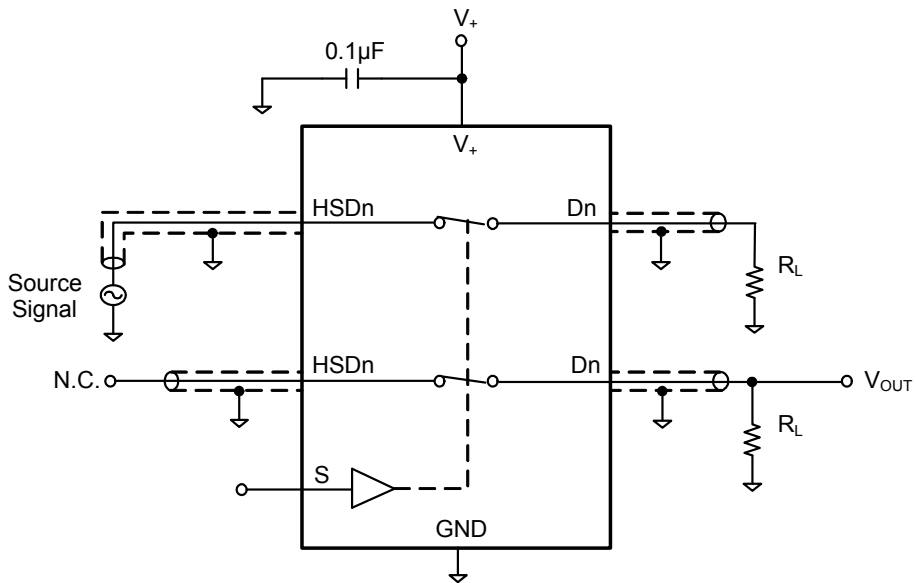

$$\text{Channel To Channel Crosstalk} = -20 \times \log \frac{V_{\text{HSDn}}}{V_{\text{OUT}}}$$

Test Circuit 5. Channel-to-Channel Crosstalk

TEST CIRCUITS (Cont.)

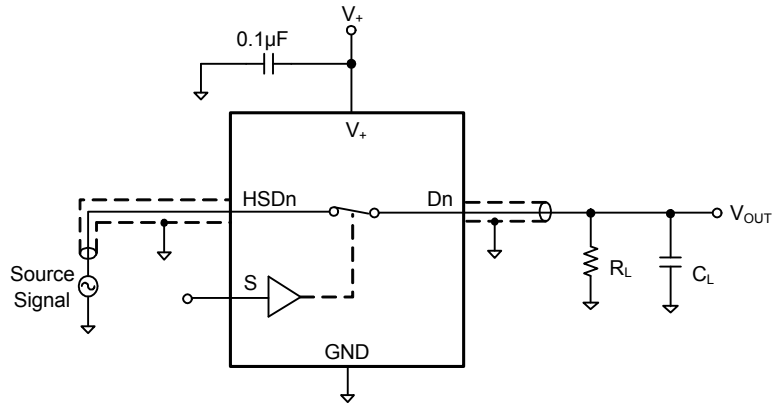

Test Circuit 6. -3dB Bandwidth

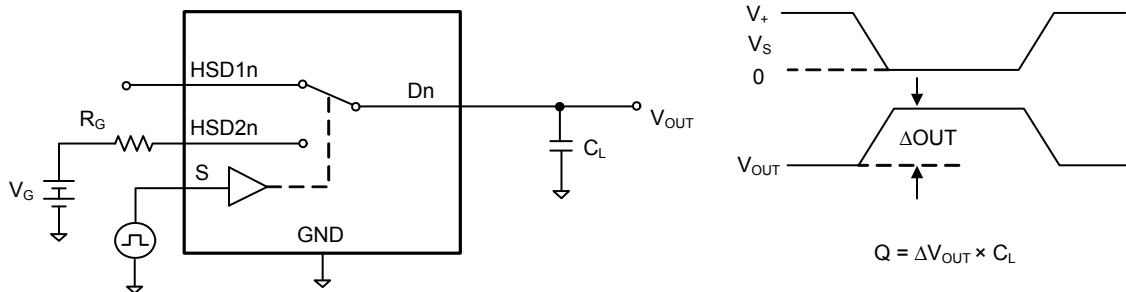

Test Circuit 7. Charge Injection (Q)

APPLICATION NOTES

Meeting USB 2.0 V_{BUS} Short Requirements

In section 7.1.1 of the USB 2.0 specification, it notes that USB devices must be able to withstand a V_{BUS} short to D+ or D- when the USB device is either powered off or powered on. The SGM7222 can be successfully configured to meet both these requirements.

Power-Off Protection

For a V_{BUS} short circuit the switch is expected to withstand such a condition for at least 24 hours. The SGM7222 has specially designed circuitry which prevents unintended signal bleed through as well as guaranteed system reliability during a power-down, over-voltage condition. The protection has been added to the common pins (D+, D-).

Power-On Protection

The USB 2.0 specification also notes that the USB device should be capable of withstanding a V_{BUS} short during transmission of data. This modification works by limiting current flow back into the V+ rail during the over-voltage event so current remains within the safe operating range. In this application, the switch passes the full 5.25V input signal through to the selected output, while maintaining specified off isolation on the un-selected pins.

SGM7222 USB2.0 Signal Quality Compliance Tests

Figures 1 and 2 show the test results for USB eye diagram tests. A summary of the USB tests is provided in Table 1. The SGM7222 passes the high speed signal quality, eye diagram and jitter tests.

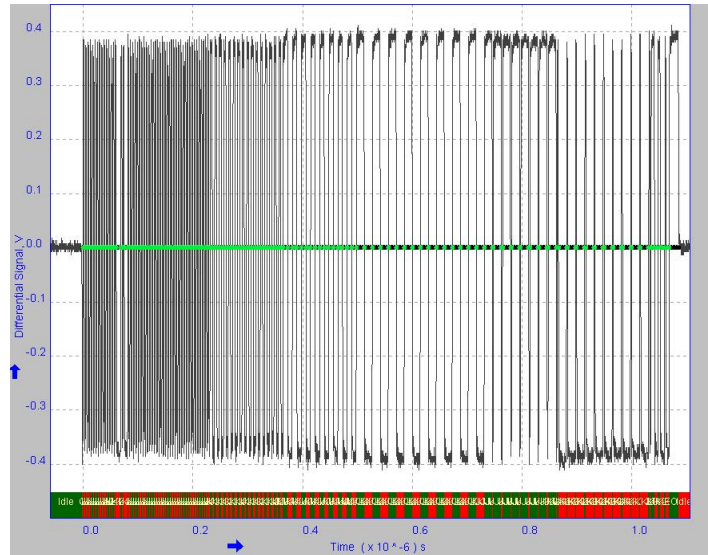

Figure 1. Waveform Plot

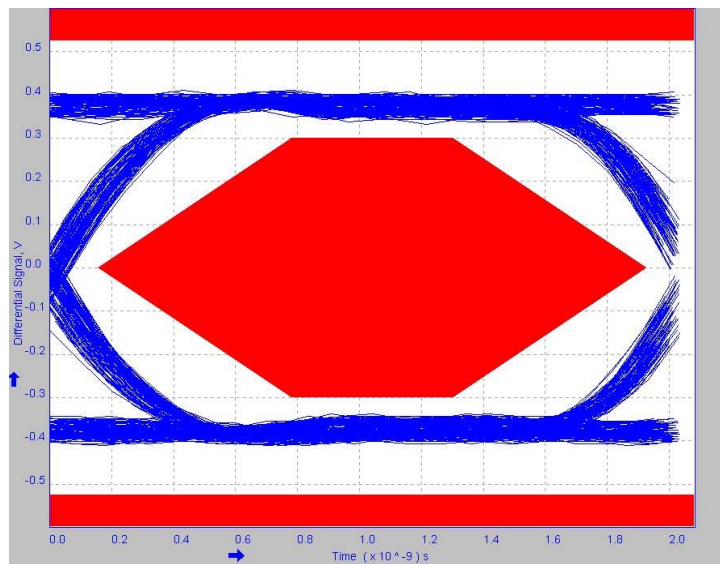

Figure 2. High Speed Signal Quality Eye Diagram Test (V+ = 3.3V)

SGM7222 USB2.0 Signal Quality Compliance Tests (Cont.)

Table 1. Summary of the USB 2.0 Signal Quality Tests Results

Measurement Name	MIN	MAX	Mean	pk-pk	Standard Deviation	RMS	Population	Status
Eye Diagram Test	-	-	-	-	-	-	-	Pass
Signal Rate	469.9358 Mbps	493.4413 Mbps	479.9700 Mbps	0.0000 bps	5.586580 Mbps	480.4200 Mbps	512	Pass
EOP Width	-	-	16.58804ns	-	-	-	1	Pass
EOP Width (Bits)	-	-	7.961762	-	-	-	1	Pass
Falling Edge Rate	1.064231 kV/ μ s	1.228955 kV/ μ s	1.143136 kV/ μ s	164.7235 V/ μ s	35.43800 V/ μ s	1.143680 kV/ μ s	107	Pass
Rising Edge Rate	1.063269 kV/ μ s	1.227966 kV/ μ s	1.136558 kV/ μ s	164.6970 V/ μ s	31.49494 V/ μ s	1.136990 kV/ μ s	108	Pass

Additional Information:

Consecutive Jitter range: -82.97ps to 72.87ps RMS Jitter 35.08ps

KJ Paired Jitter range: -25.05ps to 23.05ps RMS Jitter 9.259ps

JK Paired Jitter range: -20.96ps to 30.12ps RMS Jitter 9.734ps

- Rising Edge Rate: 1.136558kV/ μ s (Equivalent Rise Time = 563.10ps)
- Falling Edge Rate: 1.143136kV/ μ s (Equivalent Fall Time = 559.86ps)

PACKAGE OUTLINE DIMENSIONS

MSOP-10

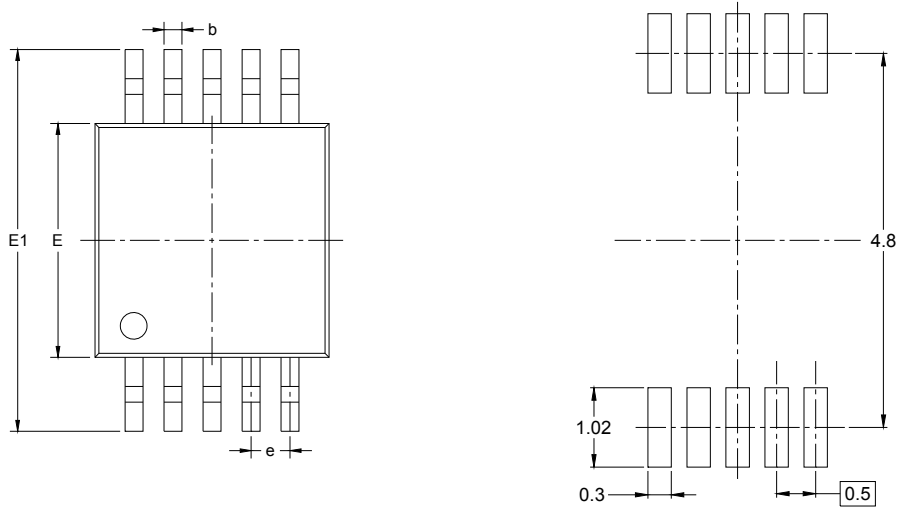

RECOMMENDED LAND PATTERN (Unit: mm)

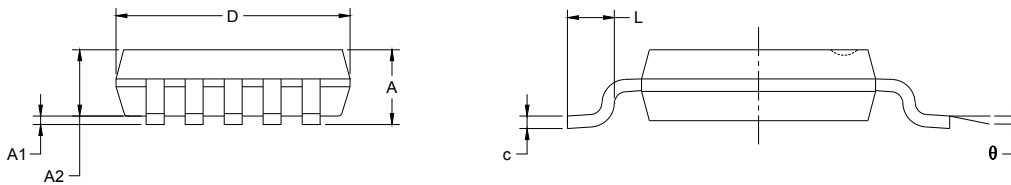

Symbol	Dimensions In Millimeters		Dimensions In Inches	
	MIN	MAX	MIN	MAX
A	0.820	1.100	0.032	0.043
A1	0.020	0.150	0.001	0.006
A2	0.750	0.950	0.030	0.037
b	0.180	0.280	0.007	0.011
c	0.090	0.230	0.004	0.009
D	2.900	3.100	0.114	0.122
E	2.900	3.100	0.114	0.122
E1	4.750	5.050	0.187	0.199
e	0.500 BSC		0.020 BSC	
L	0.400	0.800	0.016	0.031
θ	0°	6°	0°	6°

PACKAGE OUTLINE DIMENSIONS

TQFN-1.8×1.4-10L

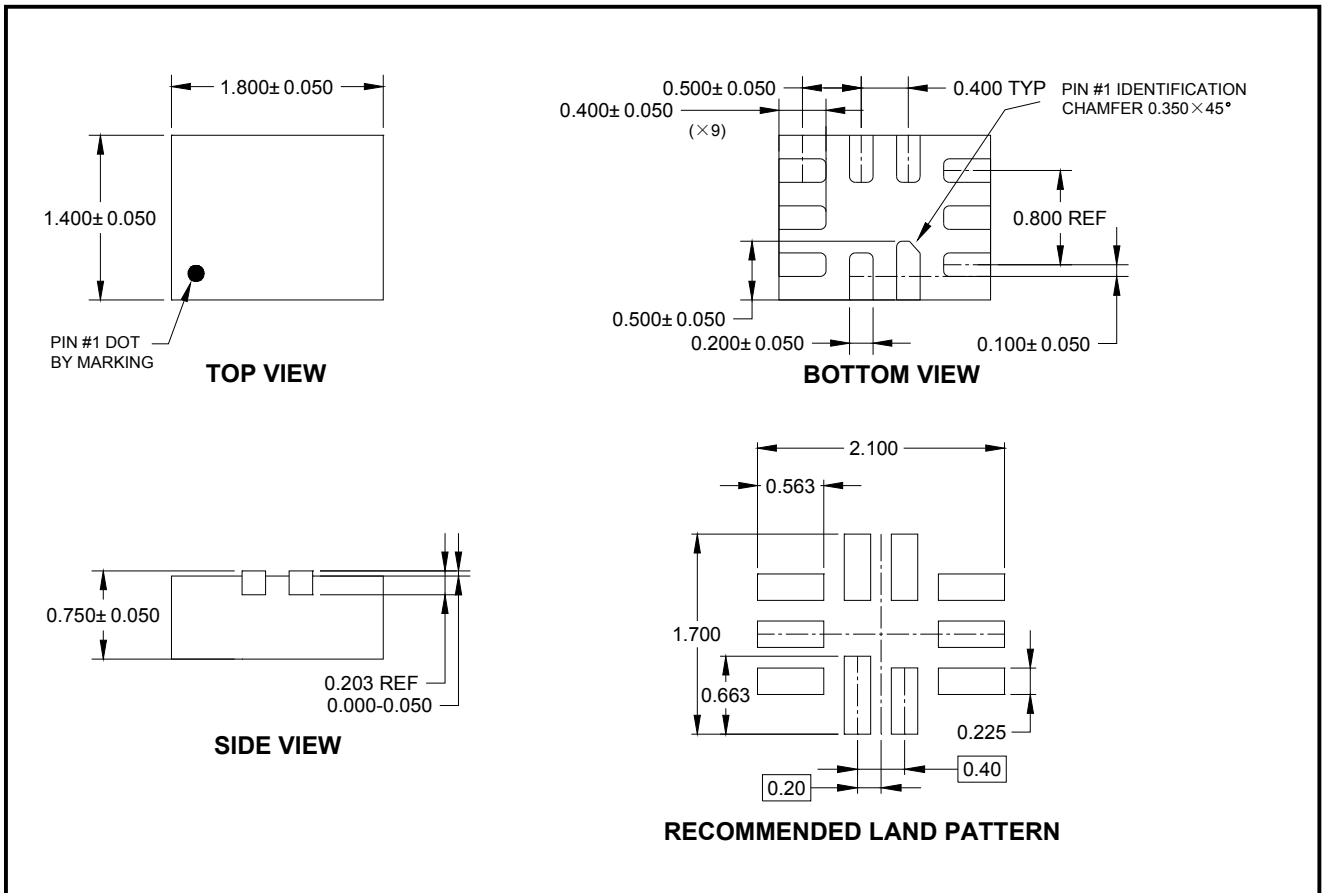

NOTE: All linear dimensions are in millimeters.

PACKAGE OUTLINE DIMENSIONS

UTQFN-1.8×1.4-10L

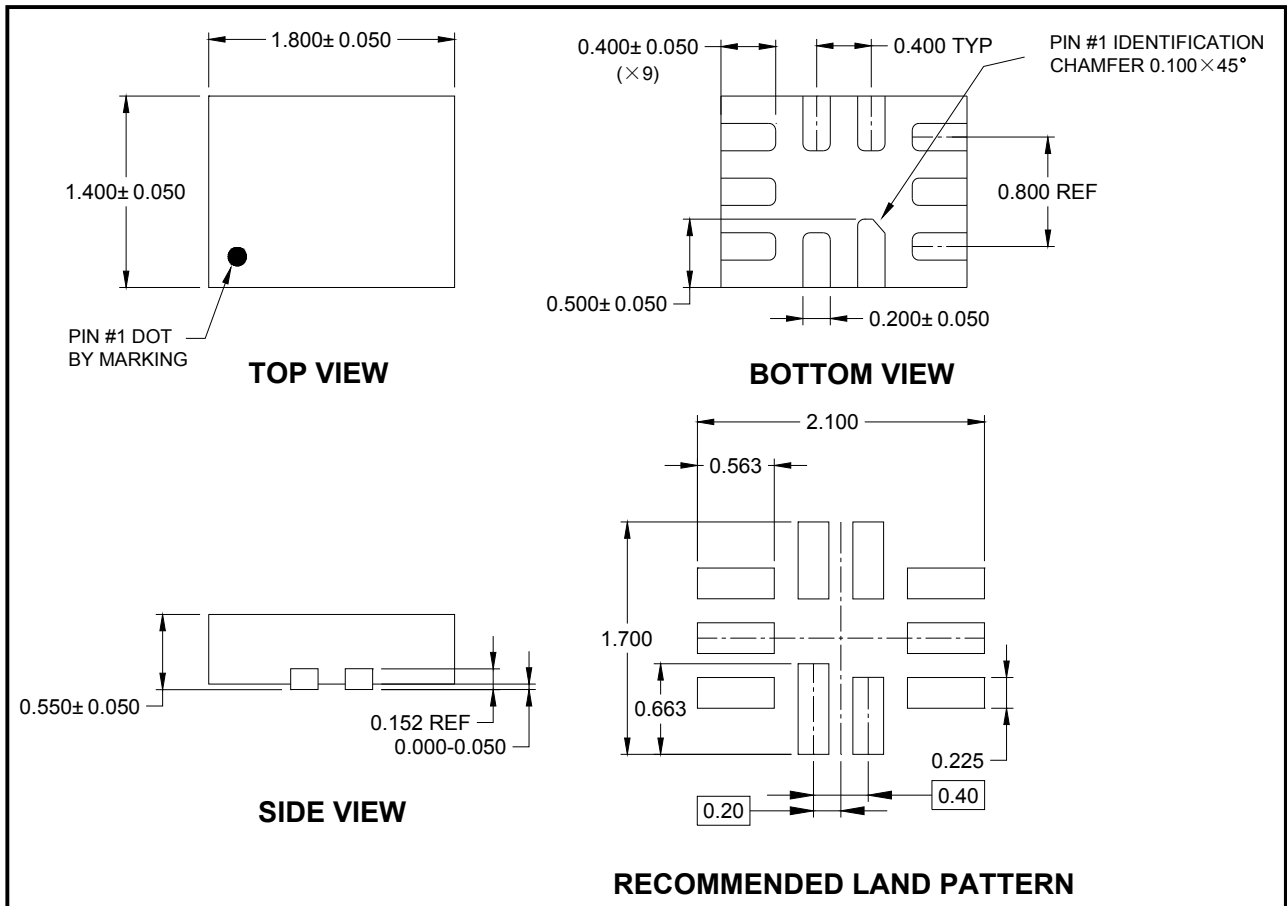

NOTE: All linear dimensions are in millimeters.

TAPE AND REEL INFORMATION

REEL DIMENSIONS

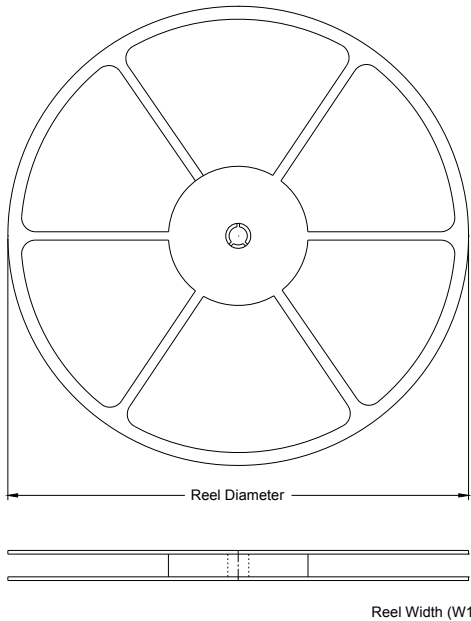

TAPE DIMENSIONS

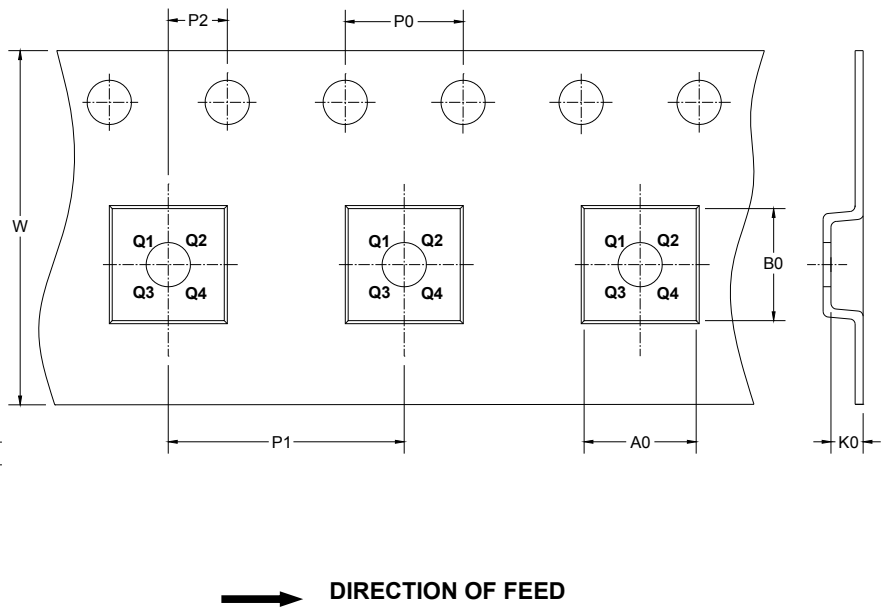

NOTE: The picture is only for reference. Please make the object as the standard.

KEY PARAMETER LIST OF TAPE AND REEL

Package Type	Reel Diameter	Reel Width W1 (mm)	A0 (mm)	B0 (mm)	K0 (mm)	P0 (mm)	P1 (mm)	P2 (mm)	W (mm)	Pin1 Quadrant
MSOP-10	13"	12.4	5.2	3.3	1.2	4.0	8.0	2.0	12.0	Q1
TQFN-1.8×1.4-10L	7"	9.0	1.75	2.10	1.00	4.00	4.00	2.00	8.00	Q1
UTQFN-1.8×1.4-10L	7"	9.0	1.75	2.10	0.70	4.00	4.00	2.00	8.00	Q1

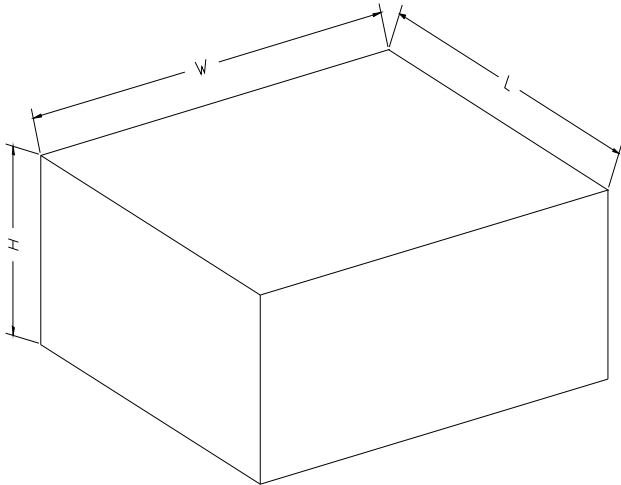
CARTON BOX DIMENSIONS

NOTE: The picture is only for reference. Please make the object as the standard.

KEY PARAMETER LIST OF CARTON BOX

Reel Type	Length (mm)	Width (mm)	Height (mm)	Pizza/Carton
7" (Option)	368	227	224	8
7"	442	410	224	18
13"	386	280	370	5